

Water the way you knew it could be.

Delicious. Convenient. Perfectly chilled drinking water.

REMOTE WATER CHILLER
DRINKING WATER ACCESSORY



A division of
WaterGroup

Hydrotech 
Your clear choice in water treatment.

This is a stylish and unique water chiller that fits discretely under the kitchen sink...ready to plug in!

- Provides perfectly chilled drinking water at 39 - 42°F (4 - 6°C)
- All stainless steel waterways to use with RO system
- White powder coated galvanized steel cabinet with light gray plastic fascia
- Easy to install with quick-connect fittings
- Four foot insulated power cord with NEMA 5-15 plug-ready to plug in
- Adjustable water temperature control
- One gallon per hour cooling capacity; stainless steel storage tank
- Air cooled; no cabinet venting required
- Includes four feet of 1/4" diameter tubing, two quick-connect fittings, wall mounting clips and screws, instruction manual
- NSF approved

Features:

Cabinet: Powder coated galvanized steel cabinet with plastic front.

Cold Water Refrigeration Unit: Convection-cooled condenser. Internally spring mounted, hermetically sealed compressor with automatic overload protector. No lubrication needed. Refrigerant is controlled accurately by capillary tube. Air-cooled; designed to fit under a cabinet.

Cold Water Thermostat: Temperature is controlled by an adjustable thermostat with "OFF" position that is easily accessible on the front of the cabinet.

Cold Water Reservoir: Evaporator is made of copper tube on stainless steel water tank and both are encapsulated in insulation.

Capacity: 1 GPH cooling capacity.

Electrical: 115 volts, 60 Hz. Water cooler compressor hp 1/20. Insulated power cord with NEMA 5-15 polarized plug.

Limited Five Year Warranty: Five year on the sealed refrigeration system and most component parts. Detailed warranty certificate enclosed with each water cooler; sample copy available upon request.

Dimensional Data

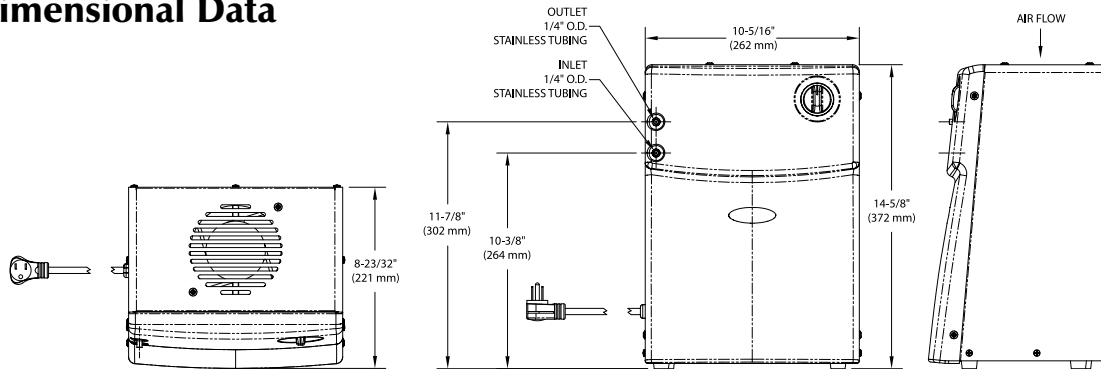

NOTE: For best performance, allow a 2" (51 mm) space around the side and the top. Do not put any objects on top of the chiller that could obstruct the fan.

Remote Water Chiller Model and System Configurations

Hydrotech Item #	Model Description	Cooling Capacity ¹ GPH (LPH)	115 volts, 60 Hz		Dimensions W x D x H Inches	Net Weight Lbs
			Full Load Amps	Rated Watts		
2878	R1P	1.0 (3.8)	1.3	135	10-5/16 x 8-3/4 x 14-5/8	30

¹Capacity is at industry standard rating conditions of 50°F (10°C) outlet water, 80°F (26.7°C) inlet water and 90°F (32.2°C) ambient air.

- Model covered by this specification complies with all known Plumbing Codes. Listed by Underwriters Laboratories Inc.
- Components in this cooler are lead free as defined by the safe Drinking Water Act Amendments of 1986, and the Lead Contamination Control Act of 1988.
- Drinking water cooler is Certified to NSF/ANSI 61.
- All specifications subject to change without notice.



Certified to NSF / ANSI 61 / Section 9

Manufactured by Tri Palm International, LLC
Cienega De Flores, Mexico

WaterGroup Inc.
Fridley, Minnesota
Mira Loma, California
1-800-354-7867

WaterGroup Companies Inc.
Cambridge, Ontario
Regina, Saskatchewan
1-877-299-5999

www.hydrotechwater.com



#57212 5/07